



# GAMMA™ WIRES

## **Gamma™**

NEXT GENERATION EDM COATED WIRE

### **SPECIAL FEATURES**

- Up To 20% Faster Than Other Coated Wire
- Up To 50% Faster Than Brass Wires
- Enhanced Flushing
- Brass-like Auto Threading
- Outstanding Cost/Benefit Ratio

## TYPES OF WIRE

### GAMMA-X®

GRADE	TENSILE STRENGTH	CORE	EXTERIOR COATING	ELONGATION	DIAMETER
X - TYPE	77,000 ± psi	COPPER	GAMMA PHASE	<10%	0.20 - 0.30mm

### GAMMA-D®

GRADE	TENSILE STRENGTH	CORE	EXTERIOR COATING	ELONGATION	DIAMETER
D - TYPE	116,000 ± psi	CuZn ALLOY	GAMMA PHASE	<3%	0.20 - 0.30mm

### GAMMA-Z®

GRADE	TENSILE STRENGTH	CORE	EXTERIOR COATING	ELONGATION	DIAMETER
HALF HARD	71,000 ± psi	HIGH ZINC BRASS	GAMMA PHASE	<15%	0.20 - 0.30mm
HARD	130,000 ± psi	HIGH ZINC BRASS	GAMMA PHASE	<2%	0.20 - 0.30mm

### GAMMA-BRASS®

GRADE	TENSILE STRENGTH	CORE	EXTERIOR COATING	ELONGATION	DIAMETER
HALF HARD	71,000 ± psi	STANDARD BRASS	GAMMA PHASE	<15%	0.20 - 0.30mm
HARD	130,000 ± psi	STANDARD BRASS	GAMMA PHASE	<2%	0.10 - 0.30mm

GAMMA-BRASS® is also sold as Z-KUT™

# GAMMA PHASE TECHNOLOGY

Gamma Phase, a proprietary technology ( US Patent #5,945,010 ) results in a outer layer of high zinc diffusion annealed gamma phase brass ( 65Zn/35Cu ). This proprietary layer significantly enhances the cutting performance of gamma phase wires as compared to diffusion annealed beta phase coated EDM wires, standard alpha phase brass wires and pure zinc coated wires.

## EVOLUTION OF EDM WIRE

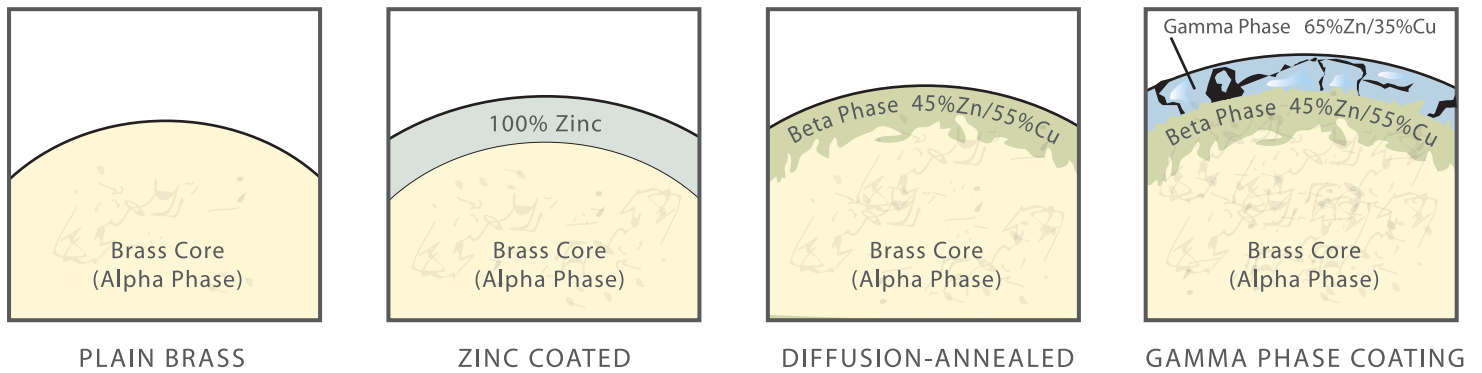

## CROSS REFERENCE GUIDE

**CONVERSIONS :** HALF HARD /  $490 \pm N/mm^2 = 71,000 \pm psi$     HARD /  $900 \pm N/mm^2 = 130,000 \pm psi$

GAMMA SERIES	GAMMA-X	GAMMA-D	GAMMA-Z (half hard)	GAMMA-Z (hard)	GAMMA-BRASS (half hard)	GAMMA-BRASS (hard)
GISCO	BroncoCut X	CobraCut-D MegaCut-D	CobraCut MegaCut-T	CobraCut-A MegaCut-A	CobraCut MegaCut-T	CobraCut-A MegaCut-A
CHARMILLES	SWX	n/a	SWS	SWA	SWS	SWA
AGIE	n/a	CobraCut-D	CobraCut	CobraCut-A	CobraCut	CobraCut-A
INTECH	BetaCut X	AlphaCut D	AlphaCut 500	AlphaCut 800	AlphaCut 500	AlphaCut 800
THERMO COMPACT	SWX, SW Sрати-Cut	SWD	SWS	SWA	SWS	SWA
STAMM	Xi, Xenon	n/a	ZC-500	ZC-900	ZC-500	ZC-900
HITACHI	n/a	HIF / HIR	HIH	HIH	HIH	HIH

# SPOOL : WEIGHT & PACKING

Spool Type	Dimension (mm)					Std. wt. lbs/kg	Spool/Box
	D <sup>1</sup>	D <sup>2</sup>	W <sup>1</sup>	W <sup>2</sup>	d		
P3	130	80	110	90	20	6.6/3.0	6
P5	160	90	114	90	20	11.0/5.0	4
P10	200	90	134	110	25	22.0/10.0	2
P20	250	110	140	110	34	44.0/20.0	1
DIN125	125	80	125	100	16	7.7/3.5	4
DIN160	160	100	160	128	22	17.6/8.0	2
DIN200	200	125	200	160	22	35.2/15.0	1
DIN250	n/a	n/a	n/a	n/a	n/a	55.0/25.0	1

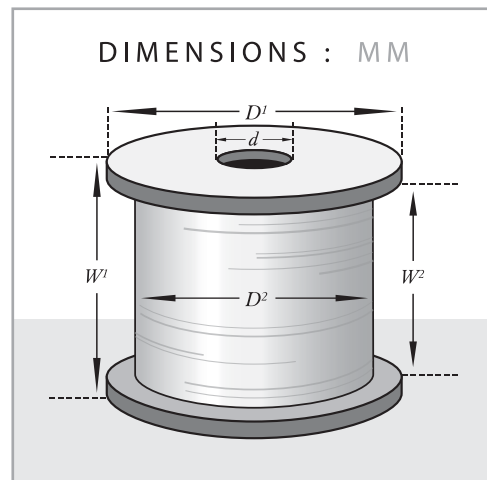

# GAMMA WIRE TEST RESULTS

RESULTS VARY WITH TYPE AND THICKNESS OF MATERIAL CUT

